

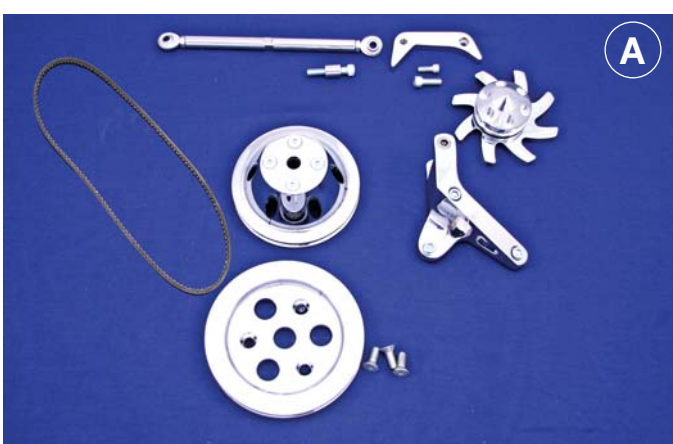

SBC (Hi-Torque) Brackets ~ V-Belt

7

7



A

Part #	HI-TORQUE BRACKET KITS V-BELT Complete kit with brackets & bars, 1 groove crank pulley, 1 groove wp pulley and 1 groove alternator pulley (Alterantor fan optional)	Natural \$ 384.95 Polished \$ 396.95 Chrome \$ 477.95
--------	------------------------------------------------------------------------------------------------------------------------------------------------------------------------	-------------------------------------------------------------



A

**SBC HI-TORQUE**  
Driver Side Alternator (only)  
w/out Power Steering, using Lg GM Alt  
w/ 10 O'Clock Adapter and  
Single Groove V-Belt Pulley Set



B

Part #	HI-TORQUE BRACKET KITS V-BELT Complete kit with brackets & bars, 1 groove crank pulley, 1 groove wp pulley and 1 groove alternator pulley (Alterantor fan optional)	Natural \$ 390.95 Polished \$ 401.95 Chrome \$ 482.95
--------	------------------------------------------------------------------------------------------------------------------------------------------------------------------------	-------------------------------------------------------------

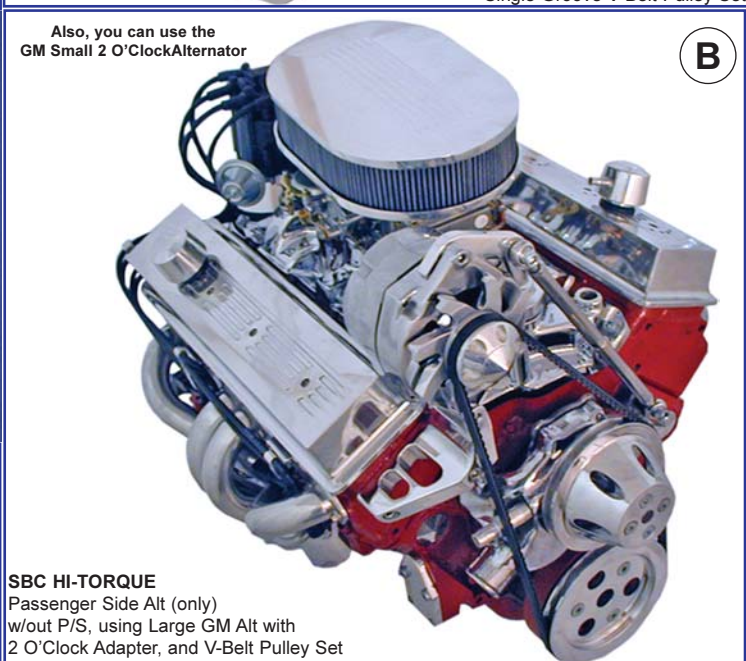

B

**SBC HI-TORQUE**  
Passenger Side Alt (only)  
w/out P/S, using Large GM Alt with  
2 O'Clock Adapter, and V-Belt Pulley Set

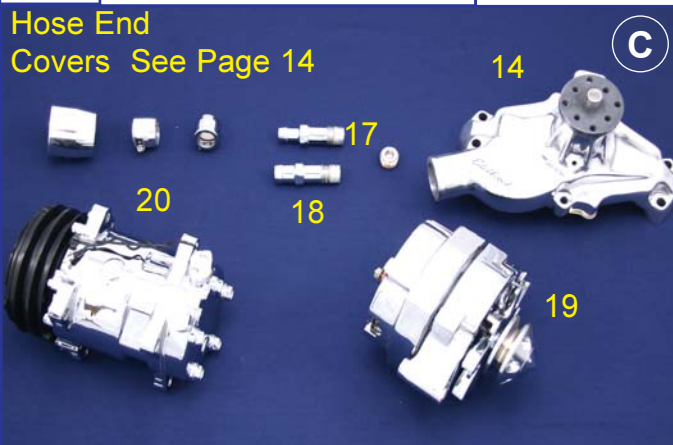

C

Hose End Covers See Page 14



Part #	HI-TORQUE V-BELT ACCESSORIES	Natural	Polish	Chrome
10000402	14. Alum Edelbrock SWP Standard Rotation	215.95	290.95	N/A
10000401	15. GM Steel Chrome Standard Rotation	-	-	135.95
10000403	16. Alum Vette Rev. Rotation 3/4" Pilot W/P	151.95	204.95	-
00000420	17. Long 1/2" pipe to 5/8" Hose Bib	N/A	19.49	21.95
00000421	18. Long 1/2" pipe to 3/4" Hose Bib	N/A	19.49	21.95
01010901	19. Alternator V-Belt	15.95	-	-
01052625	20. Air Compressor V-Belt	18.95	-	-
<b>POWER STEERING KITS &amp; ACCESSORIES</b> Includes: Bracket, Pump, Pulley & SS Adjusting Bar & Bolts				
10009101	22. SB Type I P/S Kit (for 1 or 2 Gr. Crank)	290.95	302.95	322.95
10009102	23. SB Type II P/S Kit (for 3 Gr. Crank)	290.95	302.95	322.95
0000105	"New" Aluminum Type II P/S Pump (Only)	135.95	189.95	275.95
00009402	24. S&P Alum Overflow Tank w/ Bracket	-	144.95	172.95
00009400	25. S&P Alum P/S Reservoir w/ Bracket	-	144.95	172.95
01033625	26. Power Steering V-Belt	14.95	-	-
00000424	27. 1/2" to AN8	-	17.49	20.49
00000441	28. 16mm O-ring to AN6	-	17.49	20.49

Alternator Fan and Pulley sold separately.  
Water Pumps available in Natural or Polished.  
Compressors available in R-12 or R-134A.  
Rear Exit Compressor Optional.  
Unused Compressor Mounts Removed Optional