

LT1 / LT4 Engine Vette/Camaro Style
 70

B

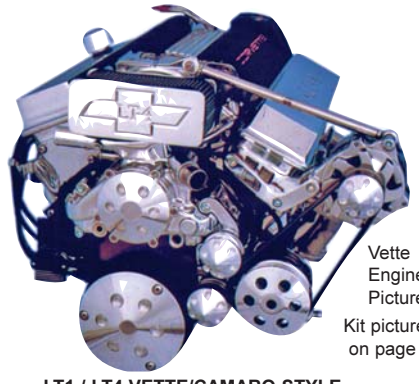

Vette Engine Pictured
Kit picture 8 on page 71

LT1 / LT4 VETTE/CAMARO STYLE
Driver Side Alt (only) using LT-1 Vette Style P/S, Small 12 O'Clock Alt, (2) Driver Side Idler Pulleys

C

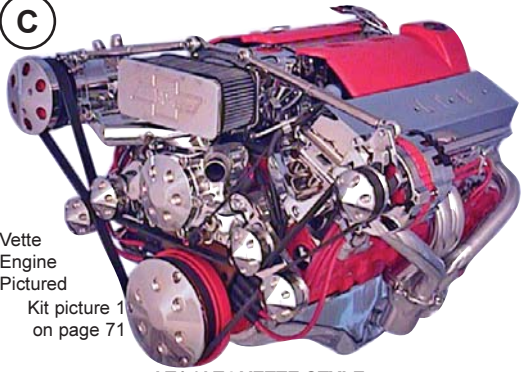

Vette Engine Pictured
Kit picture 1 on page 71

LT1 / LT4 VETTE STYLE
Driver Side Alt/Passenger Side Air w/o Power Steering, Small GM 10 O'Clock Alternator, (4) Smooth Idler Pulleys. This kit works in all 50's and later Vehicles w/o power steering

D

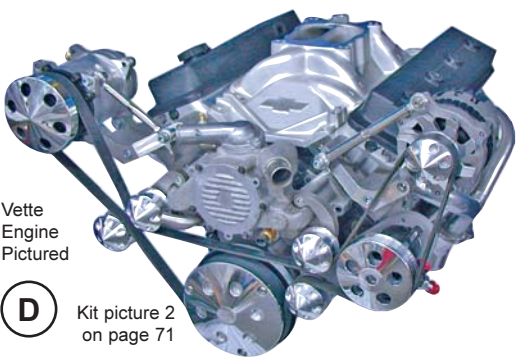

Vette Engine Pictured

Kit picture 2 on page 71

LT-1 VETTE/CAMARO STYLE W/CARBURETOR
Driver Side Alt and Pass Side Air w/Vette Style P/S with (4) Smooth Idler Pulleys

E



Vette Engine Pictured
Kit picture 1 on page 71

LT-1 VETTE/CAMARO STYLE W/CARBURETOR Driver Side Alt and Pass Side Air w/o P/S with 4 Smooth Idler Pulleys

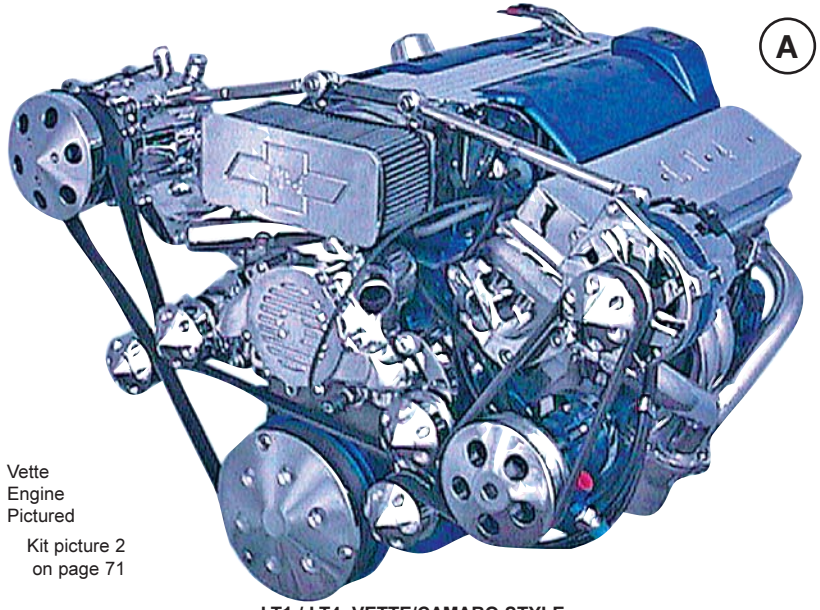

A

Vette Engine Pictured

Kit picture 2 on page 71

LT1 / LT4 VETTE/CAMARO STYLE DRIVER SIDE ALT / PASSENGER SIDE AIR
Vette Style Power Steering, Small 10 O'Clock Alternator, (4) Smooth Idler Pulleys
NOTE: CANNOT BE USED ON 57'S THAT HAVE THE BATTERY BOX IN STOCK LOCATION!
OUR MOST POPULAR VETTE/CAMARO STYLE KIT FOR 50'S AND LATER MODEL VEHICLES!

FACTORY LT-1 CORVETTE

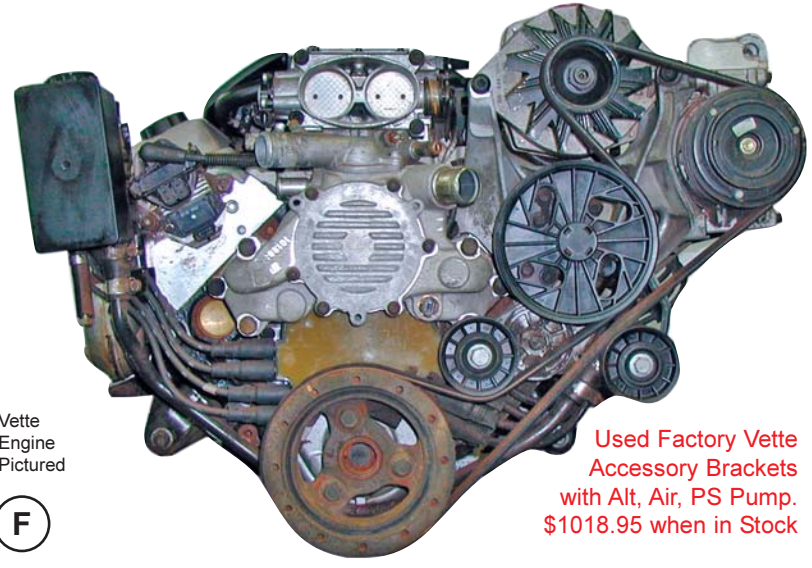

Vette Engine Pictured

F

Used Factory Vette Accessory Brackets with Alt, Air, PS Pump. \$1018.95 when in Stock

GM LT-1/LT-4 FACTORY CORVETTE

The factory Corvette LT-1 was configured with all accessories on the drivers side. Pictured above is the alternator/air, power steering configuration with the plastic reservoir on the passenger side.

G

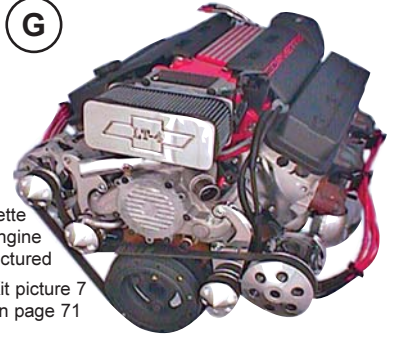

Vette Engine Pictured

Kit picture 7 on page 71

An ideal set-up for 50's and later not running A/C. 2 O'clock Alt in front of passenger side head, P/S driver side low, (2) smooth idlers

H

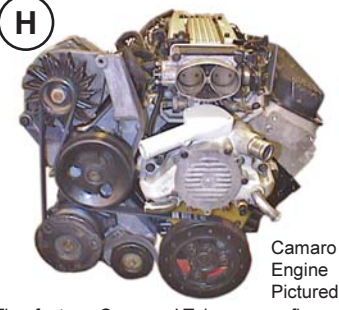

Camaro Engine Pictured

The factory Camaro LT-1 was configured with all accessories on the passenger side. Pictured above is the alt/air/power steering version of the motor.