



Street & Performance

92-93 LT-1/LT-4 16159278-88999183

Wiring Harness

09/08/2011

INSTRUCTIONS & SUPPLEMENTAL INFORMATION



Street & Performance

#1 Hot Rod Lane ~ Mena, AR 71953

479-394-5711 ~ fax 479-394-7113

email sales@hotrodlane.cc

www.hotrodlane.cc

***Visit our web ONLINE TECH page
for 24 hr service.***

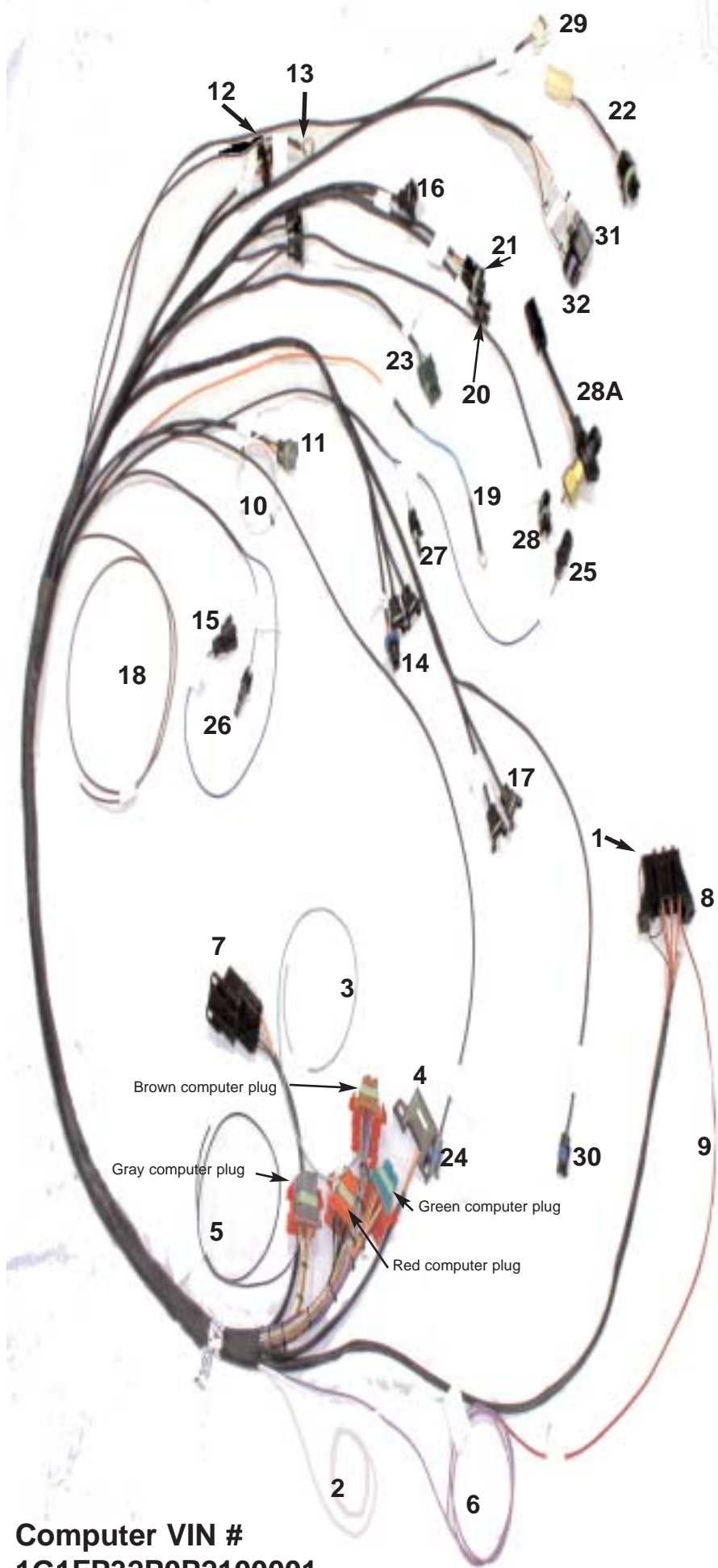

1. Check engine light / fuse panel
2. Tech wire
3. 4 K pulse for speed control
4. ALDL Connector
5. Park Neutral switch
6. Brake light switch
7. Fuel Pump Relay
8. Fuse Block
9. 12 volts crank and run
10. Oil Pressure sending unit
11. Three prong oil sending unit plug
12. Distributor plug
13. Ground wire
14. EGR Solenoid
15. Passenger side O2 sensor
16. Passenger side injector plugs
17. Driver side injector plugs
18. Hot wire to fuel pump
19. Starter battery terminal or to battery disconnect.
20. Throttle position sensor
21. Idle air motor
22. 4 Prong to 5 Prong adapter
23. MAP sensor
24. Air temp sensor
25. Driver side O2 sensor
26. Knock sensor Passenger Side
27. Knock sensor Driver Side
28. Electric vehicle speed sensor Plug
- 28A. Manual vehicle speed sensor Adapt
29. 4 Prong Transmission plug
30. Engine temp sensor
31. Coil Plug
32. Coil Driver Plug

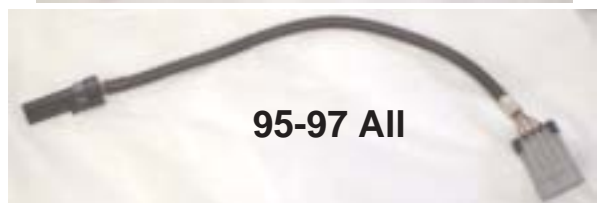
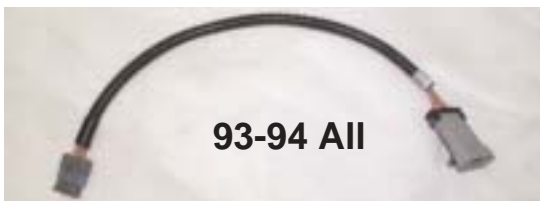

Computer VIN #
1G1FP32P0P2100001
S&P adds an extra Blue Wire for aftermarket Oil Pressure Gauge & a Green Wire for Aftermarket Coolant Temp.

94-95 LT-1 Distributor harness.
Should be saved & used from factory harness. Can be purchased from S&P

1. **Check engine light.** (Check engine light is located in the fuse panel. Can be spliced into for a remote lite)
2. **Tech wire** (White)
3. **4 K pulse for speed or cruise control** (green wire)
4. **ALDL Connector.** (used to plug in scanning tool)
5. **Park Neutral switch** (Black wire, if desired. closed in park neutral to ground)
6. **Brake light switch** (Orange wire. **Normally closed. Hot all the time the ignition is on except when brake is applied, to take the torque converter out of lock up.**) If you have the 2 prong pressure switch you will need S&P's brake switch or relay kit.(see page 8)
7. **Fuel Pump Relay** (GM part #14078915)
8. **Fuse Block**
9. **12 volts crank and run** (Red. Must have **12volts** in run position and a minimum of **10 volts** in crank position)
10. **Oil Pressure sending unit** (White wire. For use with GM gauge. with sending unit #10201491 ONLY. with after market gauges, you must use their sending unit.)
11. **Three prong oil sending unit plug** (gray plug with green seal and brown, white and orange wires. Backup system for fuel pump. Turns fuel pump off when pressure drops)
12. **Distributor plug** (Black plug with tan seal and red, yellow, purple and black wires. **Plugs into harness coming from the distributor.** The OEM distributor pig tail should be coming from the distributor.
13. **Ground wire** (black wire. Must have a good clean ground to the back of engine, and battery must ground to the engine or transmission,engine to frame and engine to body.)
14. **EGR Solenoid** (Black plug with gray seal and red & gray wire. Used only in emission vehicles)
15. **Passenger side O2 sensor** (Black plug with green seal and purple wire.)
16. **Passenger side injector plugs**
17. **Driver side injector plugs**
18. **Hot wire to fuel pump** (Single brown wire. Fused & relayed in harness. Just extended to fuel pump.)
19. **Starter battery terminal or to battery disconnect.** (Fusible link).
20. **Throttle position sensor** (Black plug with purple seal and black, gray, blue wires).
21. **Idle air motor** (Black plug with green seal and white, red, brown, yellow wires).
22. **4 Prong to 5 Prong adapter**
23. **MAP sensor** (Green Plug with green seal and gray, green, and black wires)MAP sensor must have vacuum from intake manifold.
24. **Air temp sensor** (Gray plug with blue seal and brown, black wire) With S&P air cleaner, use GM sensor #25036751 which will screw into the back plate of the air cleaner)
25. **Driver side O2 sensor** (Black plug with green seal and purple wire.)
26. **Knock sensor** (Black plug with blue wire. Driver side. Not used on IROC/TA) GM# 10456126
27. **Knock sensor** (Black plug with blue wire.Passenger side is used on all LT-1) GM# 10456126
28. **Vehicle speed sensor** (Black plug with green seal and twisted yellow and purple wires). Plugs into transmission tail housing) 120 thousand pulse per mile.
29. **4 Prong Transmission plug** (White plug with green seal and brown ,purple wires)
30. **Engine temp sensor** (Black plug with blue seal and yellow and black wires) Sensor located on water pump.
31. **Coil Plug** (Black and Gray plug zip tied together with pink and white wires)
32. **Coil Driver Plug** (Black plug with blue seal and white, black and pink wires)

Visit our website for 24 hr. tech help in trouble shooting codes.

www.hotrodlane.cc

then click on ONLINE TECH.

or call us at (479) 394-5711

LT1 HARNESS INSTRUCTIONS

Visit our web **ONLINE TECH** page for 24 hr service.

The following instructions are intended as an aid to assist in harness installation. More in depth information can be obtained by ordering the applicable GM service manual. Trouble-shooting techniques and diagnosis are beyond the scope of these instructions. Diagnostic flow charts and trouble-shooting advice are included in the service manual or S&P's web site

The general design of the harness allows for computer mounting in the glove box area or out under the hood. If placed under the hood, position the computer to where the plug-ins are pointing downward to allow for moisture drainage. Special harness lengths can be provided on an as order basis.

All harness connections are clearly tagged. The injector are pulsed simultaneously, so any injector plug can connect to any injector. However, the injector plug lengths will indicate which injector to connect and will result in a neat and professional installation.

The following information will briefly discuss the individual harness connections.

- 1.) **IGNITION:** The single ignition wire must be connected to provide 12V with the key in START (crank) and RUN position. 12V is then distributed through the fuse block to the computer (ECM), injector and coil. The fuse block has four 10 amp fuses. Each injector bank is fused as is the computer and coil. **Stock 55-57 ignition switches DO NOT allow 12v in run position**
- 2.) **MAP-SENSOR:** Manifold absolute pressure. This sensor will use original harness. Run a vacuum line from a port on the passenger side of the plenum to the port on the MAP sensor. or mount remote under passenger side fuel rail to vacuum supply when using aluminum top plate.
- 3.) **FUEL-PUMP-HOT-FEED:** Provides 12V to the fuel pump. A fuel pump relay is also provided with the harness and is energized/de-energized by the ECM. Just extended to fuel pump
- 4.) **OIL PRESSURE SENDING UNIT:** Located at the rear driver side of the manifold. It is a backup system in the event the fuel pump relay should fall. Any time oil pressure is above 5 lbs. 12V is available for the fuel pump. **White wire. For use with GM gauge with sending unit, #10201491 ONLY. With after market gauges you must use their sending unit.**
- 5.) **ENGINE GROUND:** The ground system is critical for proper operation. A good battery to motor, motor to frame, motor to body, harness ground to engine is essential.
- 6.) **BATTERY STARTER TERMINAL:** A 14 gauge fuse linked wire is connected to the starter terminal. This provides 12V (keep alive power) to the computer. If you have a battery disconnect, you must hook this wire to the hot side of the battery disconnect. It also feeds the fuel pump relay and the oil pressure sending unit.



- Street & Performance, Inc.**
- (479) 394-5711 • Fax (479) 394-7113
 - Website: www.hotrodlane.cc
 - E-mail: sales@hotrodlane.cc

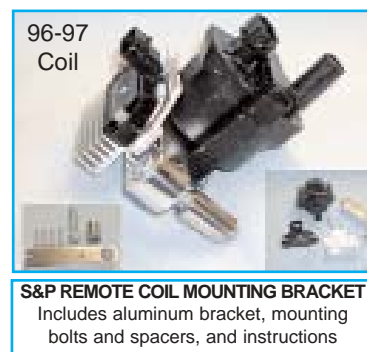

SUPPLEMENTAL INFORMATION

COMPUTER (ECM)

The ECM operates on a negative (-) ground system. Inadvertent connection of the battery leads in reverse will damage the computer. The constant battery feed to the computer should not be interrupted unless trouble codes are being erased from computer memory.

FUEL PRESSURE

For all multi port systems a high pressure electric pump is required. With Key On/Engine Off the pressure should read 45-48 lbs. With engine idling the pressure will drop off 8 to 10 lbs. **You MUST use a fuel filter that is designed for the high volume of fuel flow that is required for fuel injection such as a AC Delco GF481. Street & Performance has this filter available with mounting bracket and fittings.**

SYSTEM POWER

Full battery voltage is utilized by the injection system. Do not incorporate any ballast resistance in the ignition coil circuit or the computer ignition feed. A minimum of a 105 AMP preferably, 125 AMP or higher alternator should be used.

GAUGES

Two white wires exit the harness near the computer. One is for a tach if desired and the other is for an oil pressure gauge, (GM compatible gauges only).

DIAGNOSIS

To display diagnostic trouble codes, use a SCANNER. Grounding the DLC will not flash DTC(s), but will enable most outputs when the ignition is "ON", engine "OFF". Grounding the DLC while the engine is running will cause the MIL to flash to indicate "OPEN" or "CLOSED LOOP". This is referred to as "FIELD SERVICE MODE".

To clear the DTC's from memory use the SCANNER or:

Ignition "OFF"

Disconnect the #4 fuse (located in the instrument panel fuse block) for 30 seconds.

Since the ECM can have a failure which may affect only one circuit, following the diagnostic procedures in this section will determine which circuit has a problem and where it is.

- 7.) **THROTTLE POSITION SENSOR:** Returns a proportional voltage to the computer that relates to the angular position of the throttle plates. Relaxed throttle-low voltage (approx. 8V) wide open throttle-high voltage (approx. 4.5V). Be careful not to get TPI sensor wet when washing the engine.
- 8.) **IDLE AIR CONTROL VALVE:** Computer controlled stepper motor which adjusts engine idle at different loads.
- 9.) **COOLANT-TEMP-SENSOR:** Returns a proportional voltage to the computer that relates to the coolant temp. Cold-high voltage, hot-low voltage.
- 10.) **AIR-TEMP-SENSOR:** Operates in the same fashion as the coolant temp sensor except it relates to the air temp entering the plenum.

- 11.) **CHECK-ENGINE-LIGHT:** Check engine light is built into the fuse panel. Can be spliced into for aremote lite . ALDL plug can be jump from terminal A to B and this light will flash codes.
- 12.) **DISTRIBUTOR:** Located at the front of the motor and is crankshaft driven. This ignition system requires no initial timing adjustment. 95 needs to have the vacuum line from the distributor with the check valve must hook to the intake vacuum port and the other line needs to be routed to the air cleaner. Be careful not to get distributor wet when washing the engine. **S&P DOES NOT recommend the used of remanufactured distributors. Use only GM or AC Delco**
Street & Performance carries a complete line of LT-1/LT-4 parts

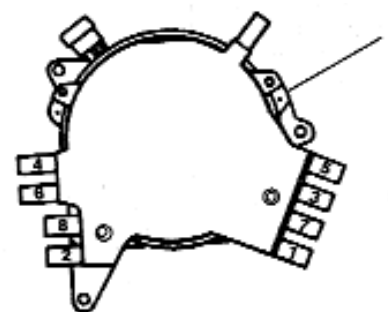
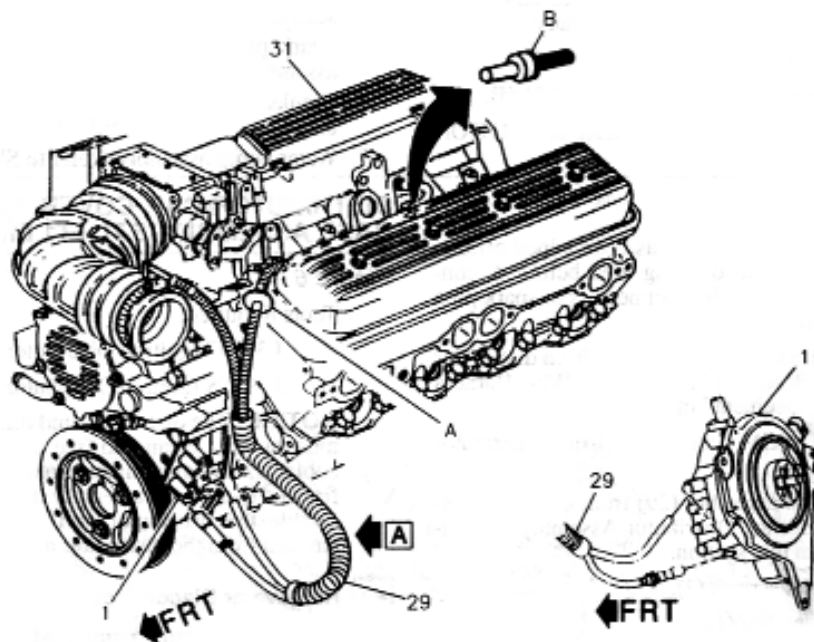

FIRING ORDER: 1 8 4 3 6 5 7 2



Replacement Vacuum lines , AC Delco distributor and accessories are available from Street & Performance

- 13.) **AUTOMATIC-LINE-DIAGNOSTIC-LINK:** ALDL, used in conjunction with the check engine light.
- 14.) **OXYGEN-SENSOR:** Four oxygen sensors are used in a factory computer configuration. Two for each engine bank, one before the catalytic converter and one after. Street & Performance can reprogram the computer to remove the rear oxygen sensors as well as other emission components for non emission vehicles only. When the exhaust temperature has reached 600 degrees F the oxygen sensor places the system in closed loop operation and maintains an air fuel ratio of 14.7 to 1. During wide open throttle conditions this input is ignored and a richer air fuel mixture is supplied.
- 15.) **KNOCK-SENSOR:** Two knock sensors are used, one for each bank. If a knock is detected the computer will automatically retard the timing. **DO NOT place Knock sensor wire close to spark plug wire.** GM# 10456126. This sensor can not be substituted for any other.
- 16.) **PARK/NEUTRAL POSITION (PNP) SWITCH:** The Park/Neutral position (PNP) switch indicates to the ECM when the transmission is in park, neutral, or drive. This information is used for the EGR and the IAC valve operation. (AUTOMATIC ONLY).EGR wire can be tied up out of the way for a NON Emission application.

- 17.) **VEHICLE SPEED SENSOR (VSS):** The Vehicle Speed Sensor (VSS) is a pulse counter type input that informs the ECM how fast the vehicle is being driven. The VSS system uses an inductive sensor mounted in the tail housing of the transmission and a toothed reluctor wheel on the tail shaft. As the reluctor rotates, the teeth alternately interfere with the magnetic field of the sensor creating an induced voltage pulse. If you do not have a programmable speedometer, S&P can program your computer chip for manual or automatic transmissions, cubic inch, injector lbs and cam shafts. Your gear ratio and tire roll out will insure proper performance and driveability.
- 18.) **Evap Canister Purge Solenoid - EGR:** Does not have to be hooked up on NON EMISSION 1974 and earlier vehicles.

S&P Polished Fuel Filter Kit.....\$79.95



Street & Performance EGR Block off Plate

SEE WEB FOR LT1 INSTALLS



Street & Performance Rear exit fuel line kit



LT1 VETTE BALANCER AND HUB

- 1. LT1 Vette Balancer - \$160.00
- 2. LT4 Balancer \$319.00
- 3. Corvette/IROC/TA Hub - \$ 67.00
- 4. Caprice Hub \$ 66.67
- 5. S&P Balancer/Spacer (IROC/TA) \$ 65.00
- 6. S&P Balancer/Spacer (Vette) \$ 75.00

IROC/TA needs item (3) to align balancer and brackets. Cast Iron Headed LT-1's need item (6) for alignment

**Street and Performance
Phone: (479) 394-5711
Fax: (479) 394-7113
www.hotrodlane.cc**

LT1 / LT4 VIDEO

S&P's LT1/LT4 video will assist you in keeping from making those costly mistakes with step-by-step instructions and troubleshooting. Your guide to fuel systems, cooling systems, transmissions, electronics for all LT series engines, 92 - 97

2 + Hours . . \$19.95

LT1/LT4 2003 Update

2003 Update offers the latest information and products. Your complete guide to fuel systems, cooling systems, transmissions, electronics for all LT series engines, 92 - 97

2+ Hours. . . \$19.95

Both Videos. . \$24.95



UPDATED 2003

Street & Performance

#1 Hot Rod Lane
 Mena, Arkansas 71953
 Ph. 479-394-5711 Fax. 479-394-7113
 www.hotrodlane.cc

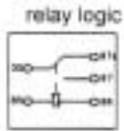

If you have a 2 prong pressure brake switch, you will need this brake switch relay kit.

BRAKE SWITCH RELAY WIRING - TCC

This set up removes the overload strain of hi-load brake lamps from the hydraulic brake switch. It is also necessary to interrupt current to the transmission torque converter lockup solenoid circuit when the brakes are applied. When the brakes are released, power is restored to the lockup solenoid power circuit.

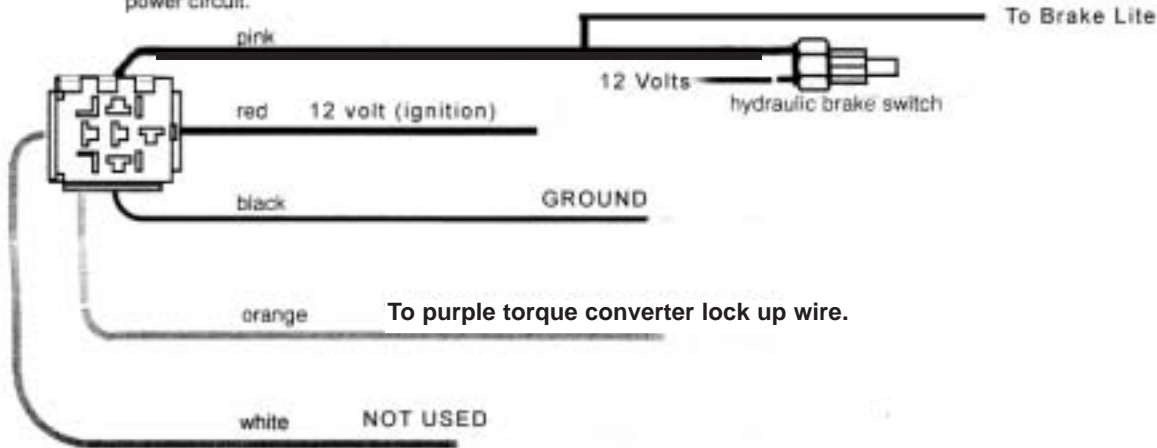

For brake light
 12 Volts with brake on ONLY

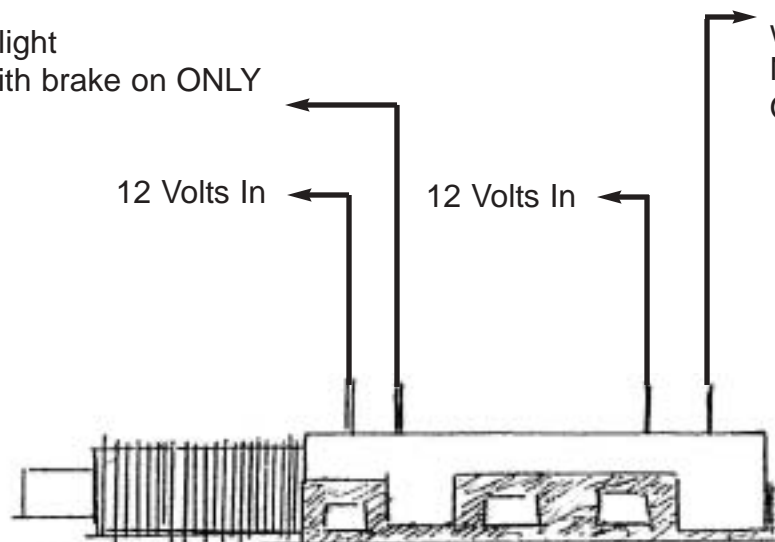

Hook to red brake wire
 12 Volts ALL THE TIME
 with brake OFF.
 NO VOLTAGE WITH BRAKE
 ON!

GM Brake Switch #25524845
 AC Delco #D850A

LT1 ('92 - '93) TROUBLE CODES

CODE #	DESCRIPTION
DTC 13	Bank 1 (Left) Oxygen Sensor (O2S) Circuit (Open Circuit)
DTC 14	Engine Coolant Temperature (ECT) Sensor Circuit (High Temp. Indicated)
DTC 15	Engine Coolant Temperature (ECT) Sensor Circuit (Low Temp. Indicated)
DTC 16	Distributor Ignition System (Low Resolution Pulse)
DTC 21	Throttle Position (TP) Sensor Circuit (Signal Voltage High)
DTC 22	Throttle Position (TP) Sensor Circuit (Signal Voltage Low)
DTC 23	Intake Air Temperature (IAT) Sensor Circuit (Low Temp. Indicated)
DTC 24	Vehicle Speed Sensor (VSS) Circuit
DTC 25	Intake Air Temperature (IAT) Sensor Circuit (High Temp. Indicated)
DTC 26	Quad-Driver Module (QDM) #1 Circuit
DTC 27	Quad-Driver Module (QDM) #2 Circuit
DTC 28	Quad-Driver Module (QDM) #3 Circuit
DTC 32	Exhaust Gas Recirculation (EGR) Circuit
DTC 33	Manifold Absolute Pressure (MAP) Sensor Circuit (Signal Voltage High-Low Vacuum)
DTC 34	Manifold Absolute Pressure (MAP) Sensor Circuit (Signal Voltage Low-High Vacuum)
DTC 36	Distributor Ignition System (Faulty High Resolution Pulse or Extra Low Resolution Pulse Detected)
DTC 41	Ignition Control (IC) Circuit (Open or Shorted Circuit)
DTC 42	Ignition Control (IC) Circuit (Grounded Circuit)
DTC 43	Knock Sensor (KS) Circuit
DTC 44	Bank 1 (Left) Oxygen Sensor (O2S) Circuit (Lean Exhaust Indicated)
DTC 45	Bank 1 (Left) Oxygen Sensor (O2S) Circuit (Rich Exhaust Indicated)
DTC 46	Personal Automotive Security System (PASS-Key 11) Circuit
DTC 51	PROM Error (Faulty or Incorrect PROM)
DTC 53	System Voltage
DTC 55	Fuel Lean Monitor
DTC 61	A/C System Performance
DTC 63	Bank 2 (Right) Oxygen Sensor (O2S) Circuit (Open Circuit)
DTC 64	Bank 2 (Right) Oxygen Sensor (O2S) Circuit (Lean Exhaust Indicated)
DTC 65	Bank 2 (Right) Oxygen Sensor (O2S) Circuit (Rich Exhaust Indicated)
DTC 66	A/C Refrigerant Pressure Sensor Circuit (Open or Shorted)
DTC 67	A/C Refrigerant Pressure Sensor Circuit (Pressure Sensor or A/C Clutch Circuit Problem)
DTC 68	A/C Relay Circuit (Shorted Circuit)
DTC 69	A/C Clutch Circuit
DTC 71	A/C Evaporator Temperature Sensor Circuit (Open or Shorted)

DIAGNOSTIC AIDS

By utilizing the ALDL plug in conjunction with a check engine light a readout of any computer trouble codes can be accomplished. To perform this operation temporarily jumper a 12V light-wires provided. Locate the ALDL plug and jump pin A to pin B. Turn the ignition on and observe the light. The first code observed should be a 12. The light will indicate the number 12 by blinking once, pausing, and blinking twice. Code 12 is not a trouble code and if no actual trouble codes have been stored the light will continue to blink a code 12. If other codes are stored the light will blink a 12 three times and then proceed to blink the next trouble code. For example, a faulty knock sensor or open/short in the knock sensor wire will set a code 43-four blinks pause three blinks. When any or all trouble codes have been read the sequence will repeat itself beginning with code 12. This will continue indefinitely as long as the key is on/engine off and pins A-B are jumpered.



A. Throttle Body ~T.P.I ~'92-'93 LT1 (One Wire)**GM# 25166816 AC DELCO# AFS21**

B. Throttle Body ~T.P.I ~'92-'93 LT1 (Three Wire)**GM# 25176708 AC DELCO# 213-632**

B2. S&P Pig Tail to convert from One Wire System to a Heated Three Wire System

C. '94-'96 LT1 Vette~ '94-'96 BUICK, CAD., '94-'97 IROC/TA (Four Wire) O2 Sensor

GM# 25312184 AC DELCO# AFS-75 C. is also used for '97-'04 LS1 Factory Corvette Engines - S&P LS1 Harness uses IROC O2 Sensor (D)

D. '98- '02 LS1 IROC/TA Engines **GM# 25312197 AC DELCO# AFS98**

E. '05 LS2 with Square Plug **GM#12587785 AC DELCO# 213-1702**



Street & Performance

#1 Hot Rod Lane
P.O. Box 1169
Mena, Arkansas U.S.A 71953

Phone 479-394-5711
Fax 479-394-7113
www.hotrodlane.cc
sales @hotrodlane.cc

LT WATER PASSAGE

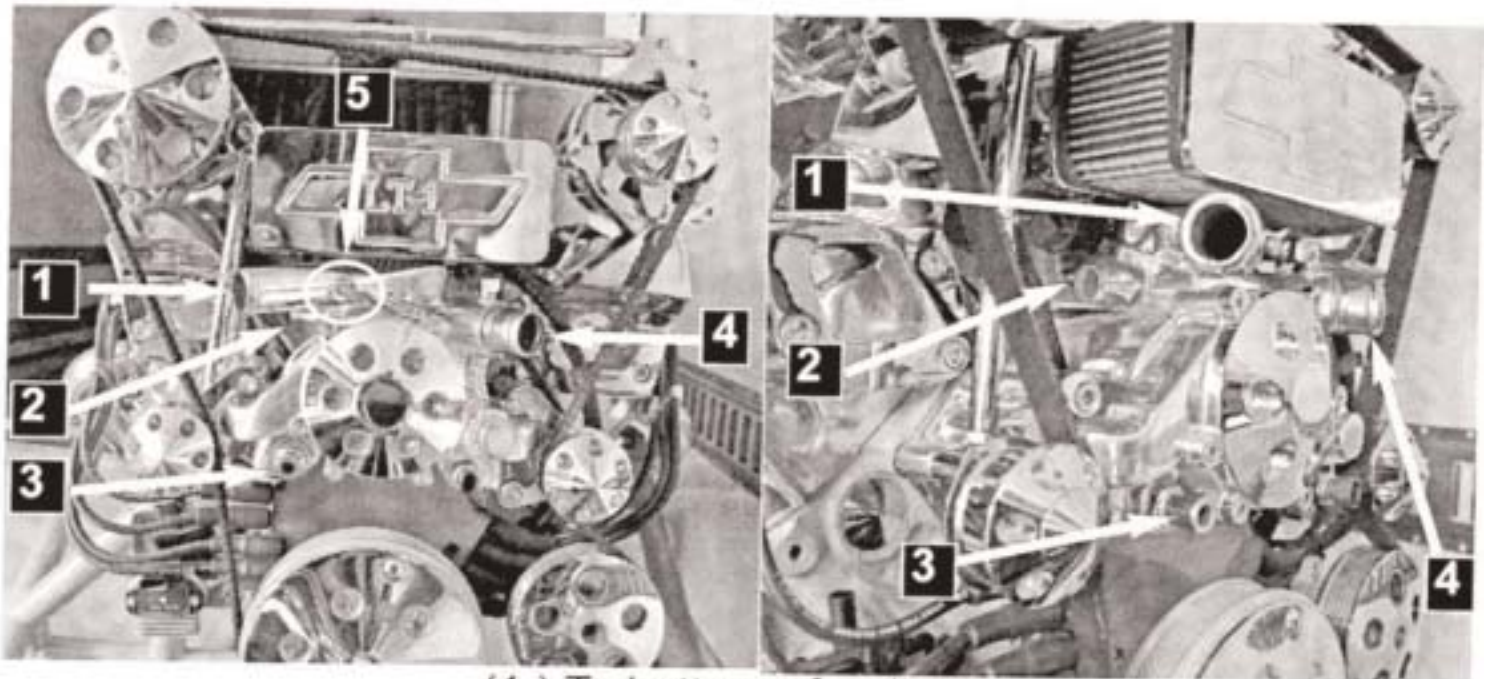

(1.) To bottom of radiator

(2.) To heater core (out from pump into heater core)

(3.) From heater core (into pump from heater core)

(4.) To top of radiator

(5.) Coolant bleed valve. Used to remove air from coolant system.



You can drill and tap the top of the water pump and install a 1/4 pipe 90 degree fitting to run a line to the bottom of the throttlebody or you can run a line from the bottom of the throttlebody to a "T" in the radiator hose. This "T" can be purchased from S&P.